

Analysis And Simulation Of Incremental Conductance MPPT Algorithm Sola PV Array Using Boosts Converter**B.Vikram, P.Vikram, M.Saimurali, R.Sruthi**¹B.Tech scholars, Dept of EEE, SVS Institute of Technology, Hanamkonda, Warangal, T.S, India
M.Ramesh²Assistant Professor, Dept of EEE, SVS Institute of Technology, Hanamkonda, Warangal, T.S, India**Abstract**

In this paper represents the modeling and simulation of the solar photo-voltaic (PV) array power generator. As the solar photo-voltaic system used the solar energy that is the renewable energies for the electric power generation. The DC voltage generated by photovoltaic system is boosted by the DCDC boost converter. The maximum power point tracking (MPPT) technique is applied for operating the photovoltaic array at the maximum power point. The Perturb and Observe (P&O) technique controls the duty ratio of boost converter for varying the load according to the maximum power point tracking.

Keywords: Modeling, Photo-voltaic Cell, MPPT, DCDC Boost Converter.**1. Introduction**

Today, environmental safety has become an important aspect for people and many industries in the world. There are many energy sources such as solar photo-voltaic system, wind turbine, and energy storage system used for generation of electricity. Solar cells are used in various field of application such as residential and industrial uses. DC power transmission is more effective than AC power transmission because of losses and efficiency [1]. Generally photo-voltaic power generation is more useful in the world than other power system. In order to obtain maximum power tracking, Perturb and Observe algorithm is used [2]. The continuous increase in the electrical power with the clean environment needs the distributed renewable energy production. The increasing energy consumption may overload the distribution solar photovoltaic grid as well as power station and May causes the negative impact on power availability, quality and security. The only solution to overcome this problem disintegrating the utility grid with the renewable energy systems like solar photovoltaic, hydro or wind energy. The smart solar grid can be connected to the renewable energy system as per the availability of renewable energy sources. Recently the solar photovoltaic power generation systems are getting more attention because solar photovoltaic energy is plentifully available, more efficient and more environment friendly as compared to the conventional power generation systems such as fossil fuel, nuclear or coal. [3]. an efficient dc-dc boost converter is used for maximum power tracking, incremental conductance technique are used [4]. Photo-voltaic array is anon linear characteristics which is a fusion of temperature and irradiance. Maximum power tracking regulators are used to extract the maximum power from solar array by imposing impedance condition that corresponds to the solar array maximum power point. Distributed generation (DG) units such as photovoltaic (PV) architectures provide several benefits compared with the central inverter systems, Including higher system availability, design flexibility, higher energy yield, and improved monitoring and diagnostic capabilities. For medium- to large-scale commercial and utility photovoltaic

(PV) systems, a string/multistring DC-Dcboosters converter topology with distributed maximum peak power tracking (MPPT), provides the best cost/performance operating point [5]. However, the implementation of such distributed system requires high-efficiency, high-performance-dc converters. Because of the high-efficiency requirements, partial power processing converters are often used as a simple way to improve the overall conversion efficiency by directly feeding forward a fraction of the input photovoltaic array power to the output DC-bus [6]. Moreover, as the supplies of fossil fuels are depleted in the future, they will become increasingly expensive. Thus, photovoltaic power is becoming more important since it produces less the environmental pollution and cost of fossil fuel energy is rising, while the cost of photovoltaic arrays is decreasing. In particular, small-capacity power distributed generation systems using photovoltaic energy may be widely used in residential and commercial applications in the near future. A dc-dc power converter is used in a small-capacity PV array power generation system to boost up the output voltage, so it can match the dc bus voltage of the inverter. The power conversion efficiency of the power conversion interface is important to insure that there is no waste of the energy generated by the photovoltaic array [3], [7]. The extensive use of fossil fuels, coal or nuclear have resulted in the global problem of greenhouse emissions [9]

2. Solar Cell Modeling

A Simulink model of a photovoltaic which is then simulated to build a PV array model in Simulink [4]. To obtain the desired high power solar cells are connected in parallel and series. The group of these PV cells is known PV module and group of PV modules is known PV array. The mathematical modeling of photovoltaic array can be described as

$$I = NpI_{ph} - NpI_d \left(\exp\left(\frac{q}{kTA} \times \frac{V_{pv}}{N_s}\right) - 1 \right) \quad (1)$$

$$I_d = Irr \left[\frac{T}{T_r} \right]^3 \exp\left(\frac{qE_g}{kA} \left[\frac{1}{T_r} - \frac{1}{T} \right]\right) \quad (2)$$

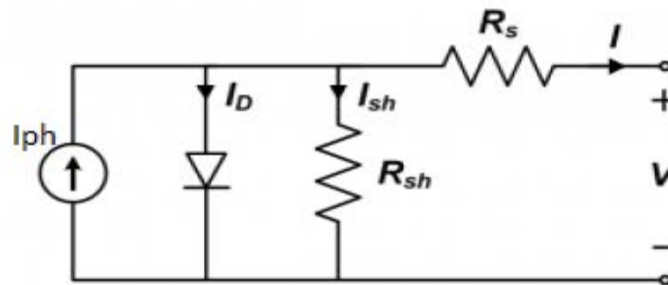

$$E_g = E_g(0) - \frac{\alpha T^2}{\beta + T} \quad (3)$$

$$I_{ph} = [I_{scr} + K_i(T - T_r)] \frac{S}{100} \quad (4)$$

The photovoltaic electric power can be given by following Expression

$$P = VI = Np \times Iph \left(\left(\frac{q}{kTA} \times \frac{V}{Ns} \right) - 1 \right) \tag{5}$$

3. Photovoltaic Module

A. Photovoltaic Module Characteristics

The solar photo-voltaic array is chosen for a Matlab/simulink, module, the solar photo-voltaic array consists of 20 series connected modules per string and 6 parallel strings. These are 36 photovoltaic cells per module and provides 13.3KW of normal maximum power. Solar temperature and irradiation plays an important role for predicting the behavior of PV array. The solar temperature affects the terminal voltage and the irradiation affects the output [8].

B. Photovoltaic Module Simulation

Below Figure shows the modeling circuit of PV module by Matlab/simulink. The solar photo-voltaic array is simulated by using the equation (1), (2), (3), (4), and (5). Temperature and Irradiance are the input of the solar photo-voltaic system. There are three remarkable points in the P-V characteristic $V_{oc} = 710$ V, $I_{sc} = 20$ A, and maximum power 13.3kW at irradiation 1000 W/m^2 and temperature 250°C .

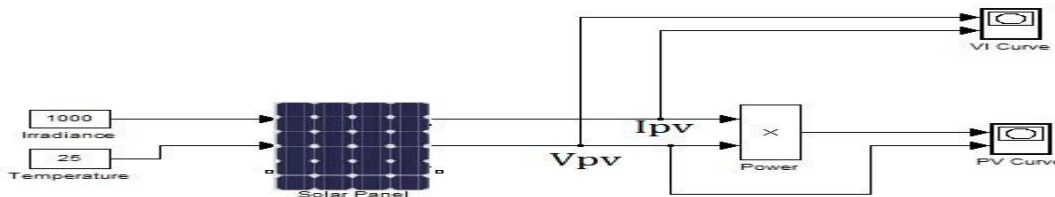

Figure 1 : Simulation of solar photovoltaic array.

The P-V characteristic of solar photo-voltaic array at 1000 W/m^2 irradiation and 250°C temperature. The Y-axis is denoted as electrical power and X-axis as voltage of PV array. The maximum power trace from PV array is about 13.3kW and open circuit voltage 710V.

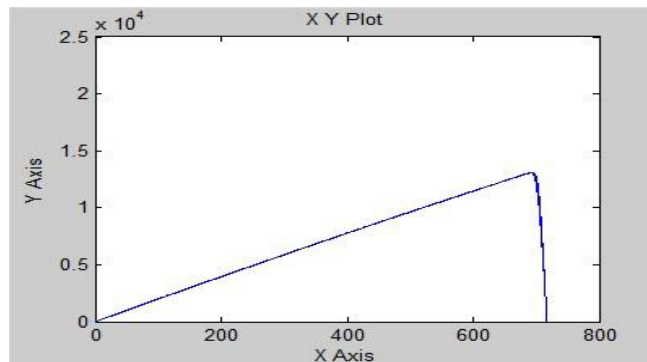

Figure 2 : P-V characterize at 250°C temperature and 1000 W/m^2 irradiance

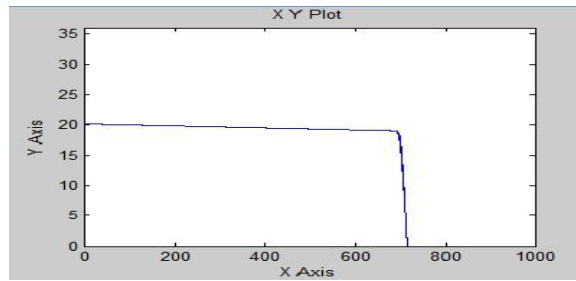

Figure 3 : P-V Characteristics at 250C temperature and 500W/m2 irradiance

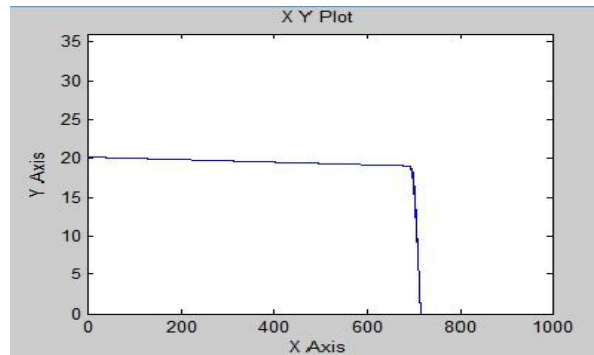

Figure 4 : V-I Characteristics at 250C temperature and 1000W/m2 irradiance.

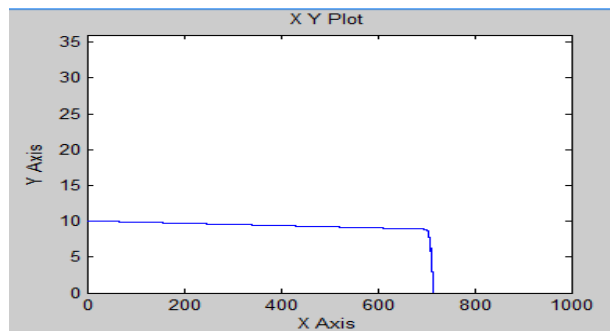

Figure 5 : V-I Characteristics at 250C temperature and 500W/m2 irradiance.

4. Boost Converter Simulation

The detailed boost converter Simulation model is and the simulation results converter for PWM Frequency 100 KHz, duty cycle $D= .5$, $L+10mH$, $C=812\mu F$, and $R=50\Omega$

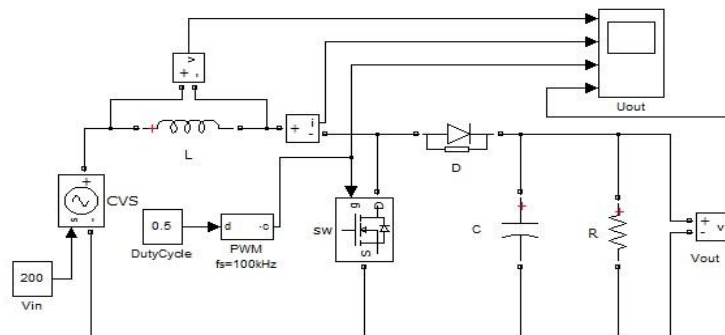

Figure 6 : Boost Converter Simulation.

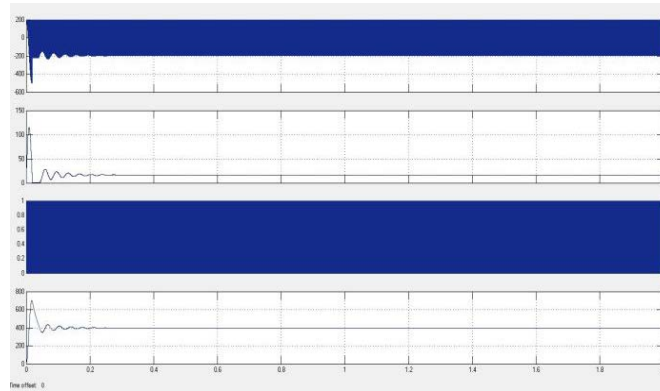

Figure 7 : Simulation Results for VL, IL, PWM, and Vout.

Due to the non-linear I-V characteristics of a solar cell their power output varies greatly depending on the voltage in which it is operating at.

5. Maximum Power Point Tracking

Also shows the maximum power point occurring at the knee of the current curve. In order to fully utilize any solar system, the voltage across the solar panel terminals needs to be monitored and controlled in such a way that it is always at the maximum power point voltage. The two most commonly used and studied control algorithms for maximum PowerPoint tracking (MPPT) are the Perturb and Observe (P&O) and the Incremental Conductance (IC) methods [3], [5]. The P&O method calculates the current output power of the solar panel. From this it “perturbs” the terminal voltage of the solar panel by incrementing or decrementing it and compares the new calculated output power to the previously calculated one. If the new value is larger, then the terminal voltage continues in the direction it was incremented or decremented.

The algorithm is operated in this fashion until the maximum power point (MPP) is achieved. However, the drawback to this method is that once the MPP is reached it continues to oscillate around this point. An attempt to fix this is to make the voltage perturbation smaller but these results in slower response to rapidly changing atmospheric conditions. The IC method was created in order to provide a better alternative to the P&O method. The basic concept of how the IC algorithm finds the MPP is based on the slope of the power curve for a solar cell. At the MPP the slope of the power curve is zero, to the left of the MPP the slope is positive, and to the right of the MPP the slope is negative. By sampling the current and voltage of the solar cell and computing the incremental and instantaneous conductance’s the MPP voltage can be determined. A detailed flowchart explaining the operation of the P&O algorithm step by step .

6. Perturb And Observe Algorithm And Simulation

In this algorithm a Perturb and Observe control method is presented to the arrangement and due to this perturbation the voltage and power of the photo-voltaic array variations. If the growths in the power due to the Perturb and Observe control method then the perturbation are continued in same direction. After the maximum power point is touched then the power at the next instant reduces hence after that situation the perturbation become opposites. When the steady state condition is touched the P&O technique oscillates around the maximum power point (MPP) [11]. Due to the electrical power variation low the size of perturbation is kept smaller

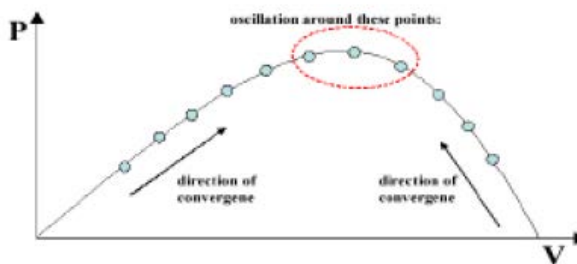

Figure 8 : Perturb and observe algorithm.

Perturb and Observe (P&O) control method algorithm. The P&O algorithm delivers the value of voltage and current from the solar photovoltaic array. The product of voltage and current is the power of solar photo-voltaic array [10]. The worth of solar photovoltaic module voltage and power at kth instant are kept. Again the solar photo-voltaic power is calculated at next value (k+1)th instant from the measured value of voltage and current. At (k+1)th instant the voltage and power are subtracted with the values from kth instant

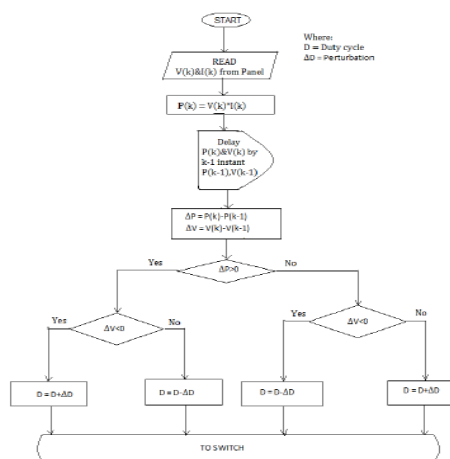

Figure 9 : Perturb and observe flow chart

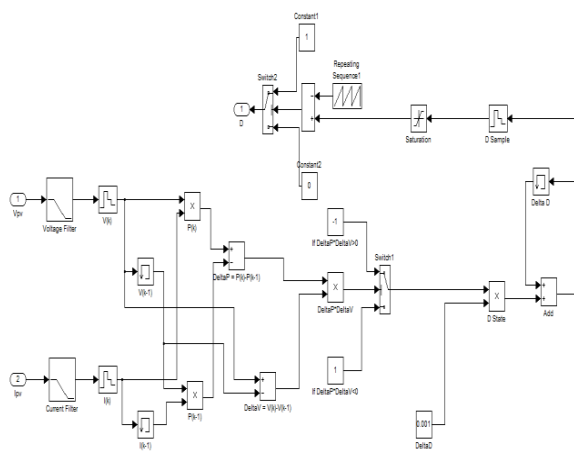

Figure 10 : Perturb and observe algorithm simulation.

The detailed matlab/Simulink model. The photo-voltaic voltage (V_{pv}) and current (I_{pv}) are taken as the perturbation inputs from solar photo-voltaic array module to MPPT unit, duty cycle D is obtained as output [12].

7. System Simulation

The complete system simulation. It contains all the apparatuses seen before, the photovoltaic, MPP tracker using P&O technique. Boost converter, and resistive load. The simulation has done for a gradual change of solar irradiance from 500 to 1000W/m²

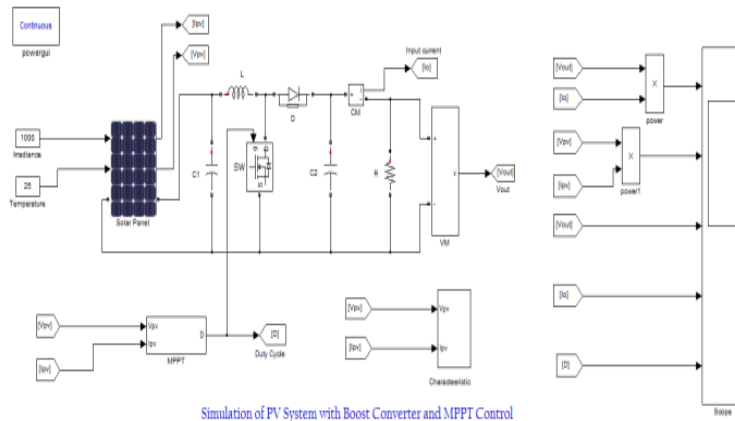

Figure 11: Simulation of whole System.

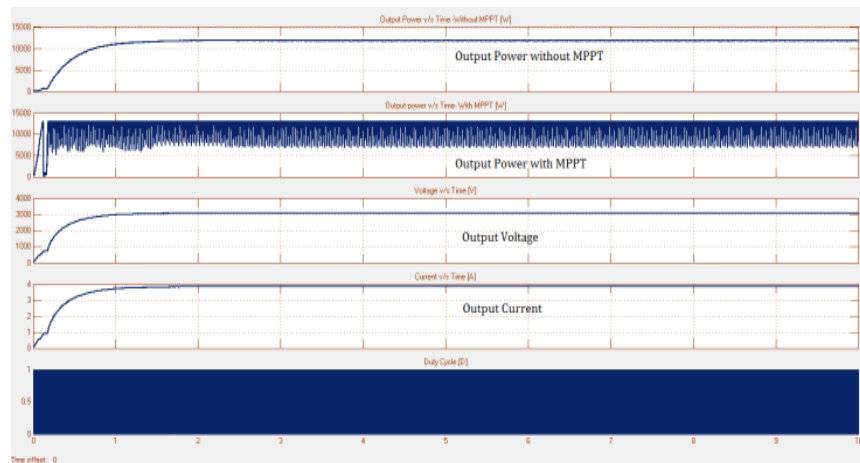

Figure 12: Output of the PV system at 250C Temperature and 1000 W/m² Irradiance

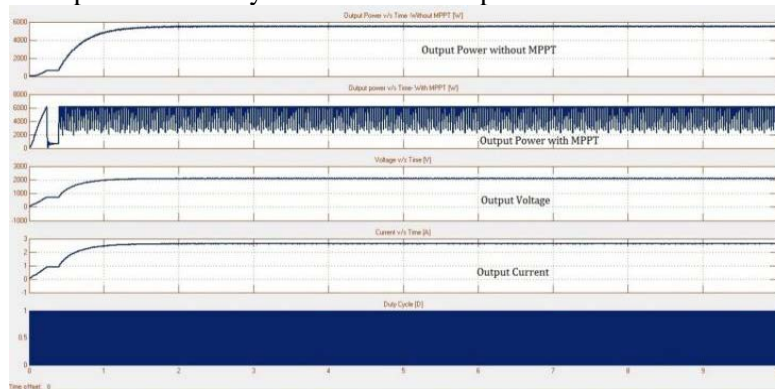

Figure 13: Output of the PV system at 250C Temperature and 500 W/m² Irradiance

8. Conclusion

The main purpose of this paper to establish a proposed simulation model for solar photovoltaic system was performed along with perturb and observe technique for maximum peak power tracking. For improvement in the electrical energy efficiency and power quality issues with the increment of world's electrical power demand, the electric power generation by using the renewable energy technologies units such as solar photovoltaic and wind energy are the only solution. There are so many countries in the world located in the tropical and temperature regions, where the direct sunlight density may reach up to 1000W/m². Hence solar photovoltaic system is considered as a primary resource. The boost converter is used to step up the PV array output with the perturb and observe technique for controlling the duty ratio of boost converter switch SW.

9. References

- [1]. Krishna Shenai and Krushal Shah, "Smart DC Micro-grid for Efficient Utilization of Distributed Renewable Energy" Digest of IEEE Applied Power Electronics Conference and Exposition, 2011.
- [2]. Wenhao Cai, Hui Ren, Yanjun Jiao, Mingwei Cai, Xiangpu Cheng, "Analysis and Simulation for Grid-Connected Photovoltaic System based on Matlab" IEEE 2011.
- [3]. Sweeka Meshram, Ganga Agnihotri and Sushma Gupta. "An Efficient Constant Current Controller for PV Solar Power Generator Integrated with the Grid" IEEE Applied Power Electronics Conference and Exposition, 2012.
- [4]. Syam M S, T.Sreejith Kailas, "Grid Connected PV System using Cuk Converter" International Conference on Microelectronics, Communication and Renewable Energy (ICMiCR-2013).
- [5]. Ahmed K. Abdelsalam, Ahmed M. Massoud, Shehab Ahmed, and Prasad N. Enjeti. "High-Performance Adaptive Perturb and Observe MPPT Technique for Photovoltaic-Based Microgrids" IEEE Trans. Power electron. , vol.26,no.4, pp.1010-1021 April 2011.
- [6]. Mohammed S. Agamy, Song Chi Ahmed Elasser, Maja Harfman Todorovic, Yan Jiang, Frank Mueller, and Fengfeng Tao A, "A High-Power-Density DC-DC Converter for Distributed PV Architectures" IEEE Journal of Photovoltaics vol.3,no.2, pp.791-798 April 2013.
- [7]. Jinn-Chang Wu and Chia-Wei Chou, "A Solar Power Generation System With a Seven-Level Inverter" IEEE Trans. Power electron vol.29,no.7 .pp.3454-3462 July 2014.
- [8]. Jungmoon Kim and Chulwoo Kim, "A DC-DC Boost Converter With Variation-Tolerant MPPT Technique and Efficient ZCS Circuit for Thermoelectric Energy Harvesting Applications" IEEE Trans. Power electron. , vol.28,no.8, pp.3827-3837 August 2013. 9 "Solar Photovoltaics: Status, Costs, and Trends," EPRI, Palo Alto, 1015804, 2009.
- [9]. G.El-Saady, El-Nobi A.Ibrahim, and Mohamed ELHendawi, "Simulated Annealing Modeling and Analog MPPT Simulation for Standalone Photovoltaic Arrays" International Journal on Power Engineering and Energy (IJPEE) Vol.4, no.1, pp. 353-360 January 2013.
- [10]. Wu Libo, Zhao Zhengming, Liu Jianzheng, "A Single-Stage Three-Phase Grid-Connected Photovoltaic System With Modified MPPT Method and Reactive Power Compensation" IEEE Trans. Energy Convers, vol. 22, no. 4, pp. 881-886 December 2007.

- [11]. S. Alsadi, B.Alsayid, “Maximum Power Point TrackingSimulation for Photovoltaic” International Journal ofEngineering and Innovative Technology (IJEIT) Vol.2,Issue 6,pp.80-85 December 2012.
- [12]. Dr. P.S. Bimbhra, Power Electronics, KhannaPublishers, New Delhi, 2012.International Journal of Engineering Research & Technology (IJERT)